

STP01-DRU01-SS-EX

SWL : 350KG

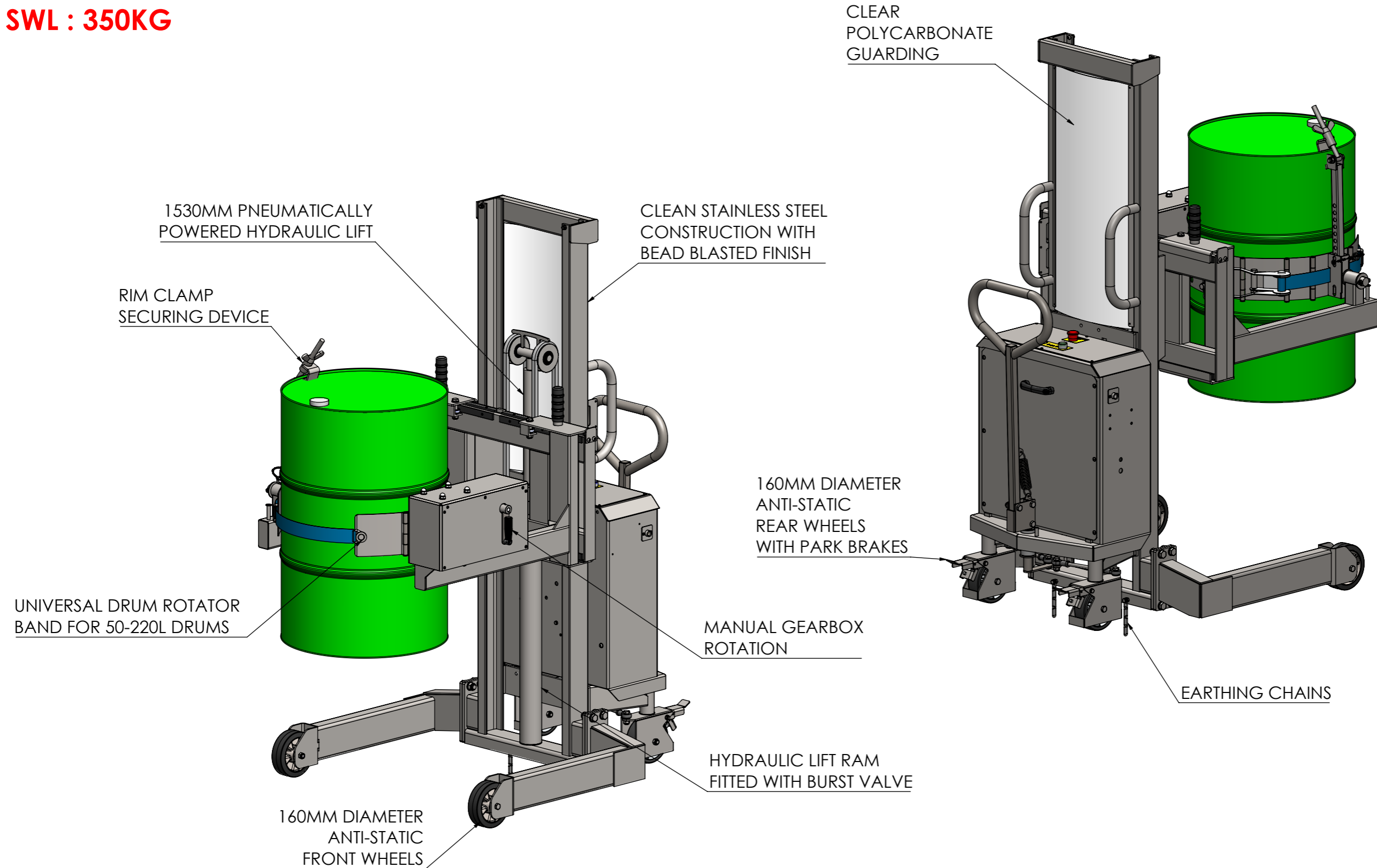

TECRAM
 Route d'Yverdon 34 · CH-1373 Chavornay
 +41 24 441 42 40 · info@tecram.ch · www.tecram.ch

THIRD ANGLE PROJECTION

ALL DIMENSIONS IN mm U.O.S
DO NOT SCALE



BESPOKE HANDLING EQUIPMENT LTD
 LEEDSTOWN, CORNWALL, TR27 6DS
 TEL: +44 1736 85 10 50 FAX: +44 1736 85 10 23
 E-MAIL: SALES@STS-TROLLEYS.CO.UK
 WWW: HTTPS://WWW.STS-TROLLEYS.CO.UK

CUSTOMER APPROVAL:

NAME:

SIGNATURE:

DATE:

THIS DOCUMENT AND ALL THE INFORMATION CONTAINED HEREIN ARE CONFIDENTIAL AND EXCLUSIVE PROPERTY OF STS BESPOKE HANDLING EQUIPMENT AND MAY NOT BE REPRODUCED, USED, DISCLOSED OR MADE PUBLIC IN ANY MANNER PRIOR TO EXPRESS WRITTEN AUTHORIZATION BY STS BESPOKE HANDLING EQUIPMENT.
 THIS DOCUMENT IS ACCEPTED PURSUANT TO AGREEMENT TO THE FOREGOING, AND MUST BE RETURNED OR DESTROYED UPON DEMAND.
 MANUFACTURER AGREES THAT ARTICLES MADE IN ACCORDANCE WITH THIS DOCUMENT SHALL BE CONSIDERED STS BESPOKE HANDLING EQUIPMENT'S DESIGN AND THAT IDENTICAL ARTICLES OR PARTS THEREOF SHALL NOT BE MANUFACTURED FOR THE USE OR SALE BY THE MANUFACTURER OR ANY OTHER PERSON OR ENTITY WITHOUT PRIOR EXPRESS WRITTEN AUTHORIZATION BY STS BESPOKE HANDLING EQUIPMENT.

CATEGORY: ASSEMBLY

MATERIAL SPEC:

FINISH: N/A

DESCRIPTION: STP01-DRU01-SS-EX, ATEX RATED STAINLESS STEEL PNEUMATIC-HYDRAULIC STACKER WITH A MANUALLY ROTATED UNIVERSAL DRUM BAND, 350KG SWL

SHEET NO: 1 OF 5	DRAWN BY: JS
EST MASS: 639.00kg	CHECKED BY:
SHEET SIZE: A3	DATE CHK:
PART NUMBER: 018318	REVISION: B

R1450
TURNING RADIUS

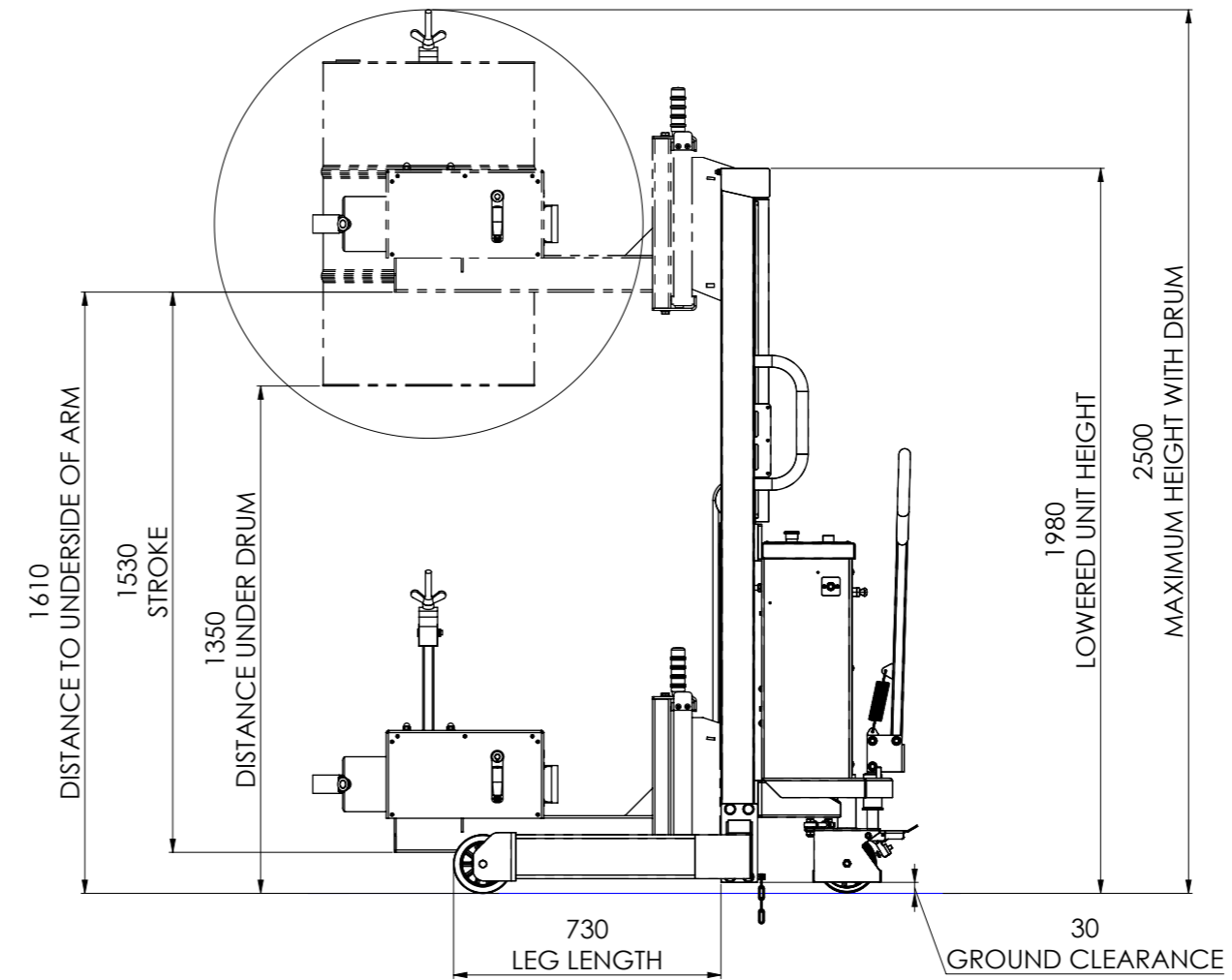
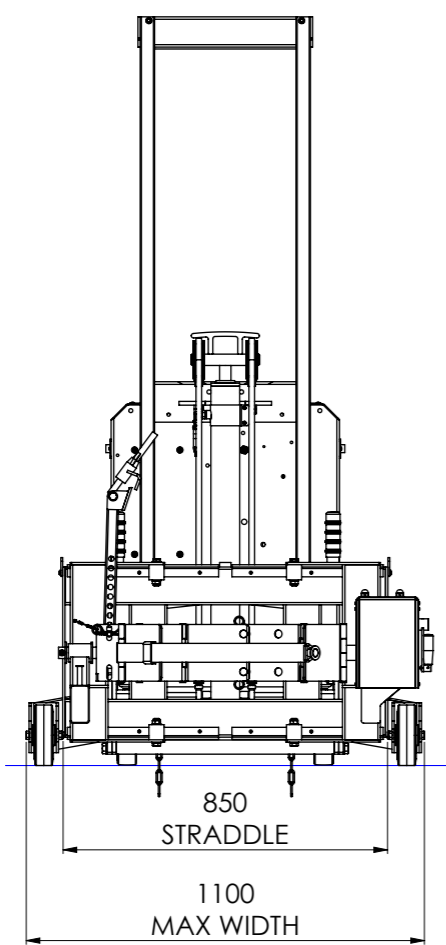
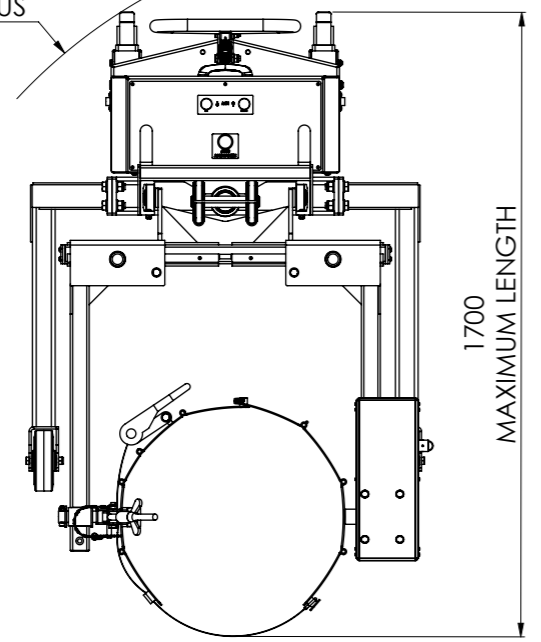

Route d'Yverdon 34 · CH-1373 Chavornay
+41 24 441 42 40 · info@tecram.ch · www.tecram.ch

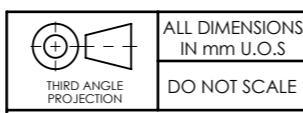

ALL DIMENSIONS
IN mm U.O.S
DO NOT SCALE



BESPOKE HANDLING EQUIPMENT LTD
LEEDSTOWN, CORNWALL, TR27 6DS
TEL: +44 1736 85 10 50 FAX: +44 1736 85 10 23
E-MAIL: SALES@STS-TROLLEYS.CO.UK
WWW: HTTPS://WWW.STS-TROLLEYS.CO.UK

CUSTOMER APPROVAL:
NAME:
SIGNATURE:
DATE:

THIS DOCUMENT AND ALL THE INFORMATION CONTAINED HEREIN ARE CONFIDENTIAL AND EXCLUSIVE PROPERTY OF STS BESPOKE HANDLING EQUIPMENT AND MAY NOT BE REPRODUCED, USED, DISCLOSED OR MADE PUBLIC IN ANY MANNER PRIOR TO EXPRESS WRITTEN AUTHORIZATION BY STS BESPOKE HANDLING EQUIPMENT.
THIS DOCUMENT IS ACCEPTED PURSUANT TO AGREEMENT TO THE FOREGOING, AND MUST BE RETURNED OR DESTROYED UPON DEMAND.
MANUFACTURER AGREES THAT ARTICLES MADE IN ACCORDANCE WITH THIS DOCUMENT SHALL BE CONSIDERED STS BESPOKE HANDLING EQUIPMENT'S DESIGN AND THAT IDENTICAL ARTICLES OR PARTS THEREOF SHALL NOT BE MANUFACTURED FOR THE USE OR SALE BY THE MANUFACTURER OR ANY OTHER PERSON OR ENTITY WITHOUT PRIOR EXPRESS WRITTEN AUTHORIZATION BY STS BESPOKE HANDLING EQUIPMENT.

CATEGORY: ASSEMBLY
MATERIAL SPEC:
FINISH: N/A

DESCRIPTION: STP01-DRU01-SS-EX, ATEX RATED STAINLESS STEEL PNEUMATIC-HYDRAULIC STACKER WITH A MANUALLY ROTATED UNIVERSAL DRUM BAND, 350KG SWL

SHEET NO: 2 OF 5
EST MASS: 639.00kg
SHEET SIZE: A3
PART NUMBER: 018318

DRAWN BY: JS
CHECKED BY:
DATE CHK:
REVISION: B

TIPPING HEIGHTS

TIP OF 15°

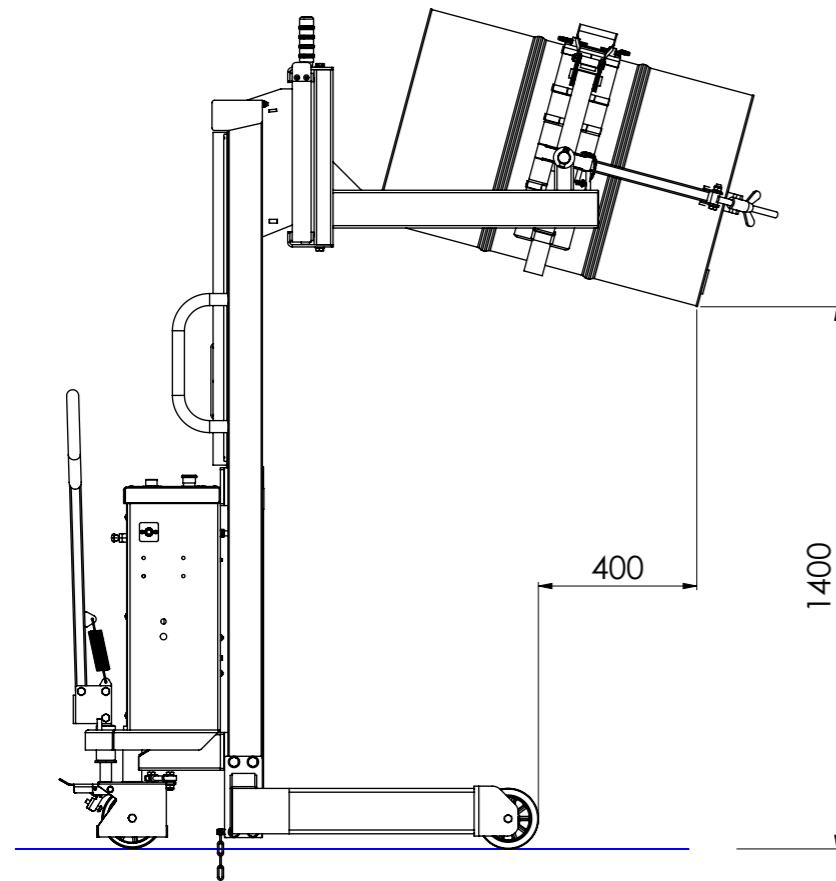

TIP OF 30°

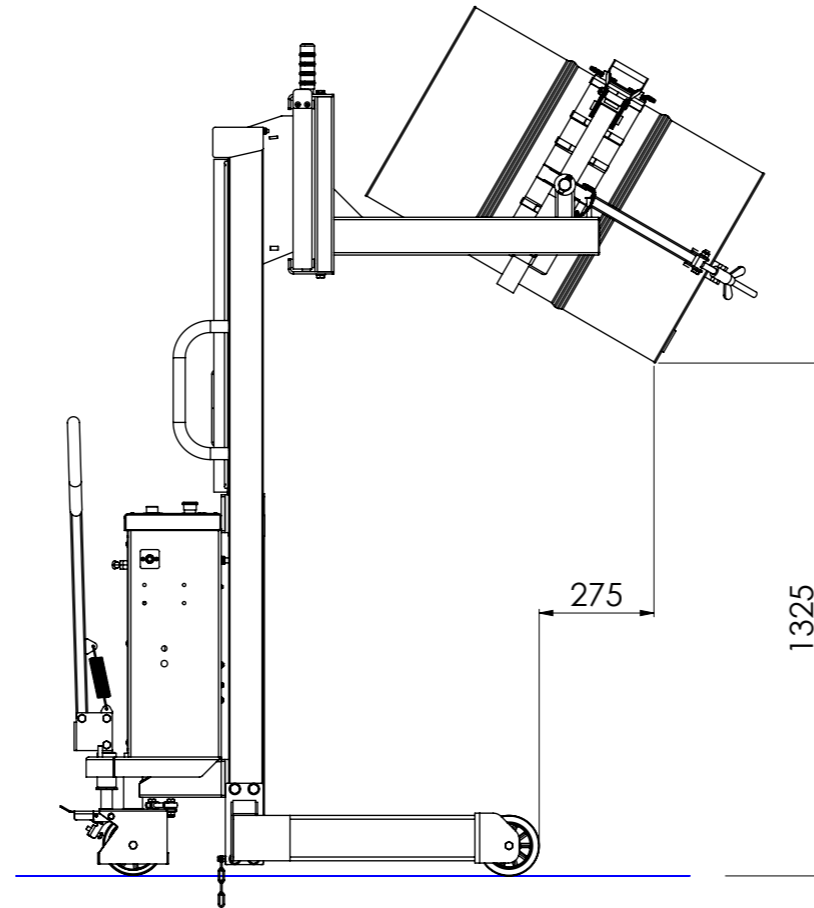

TIP OF 60°

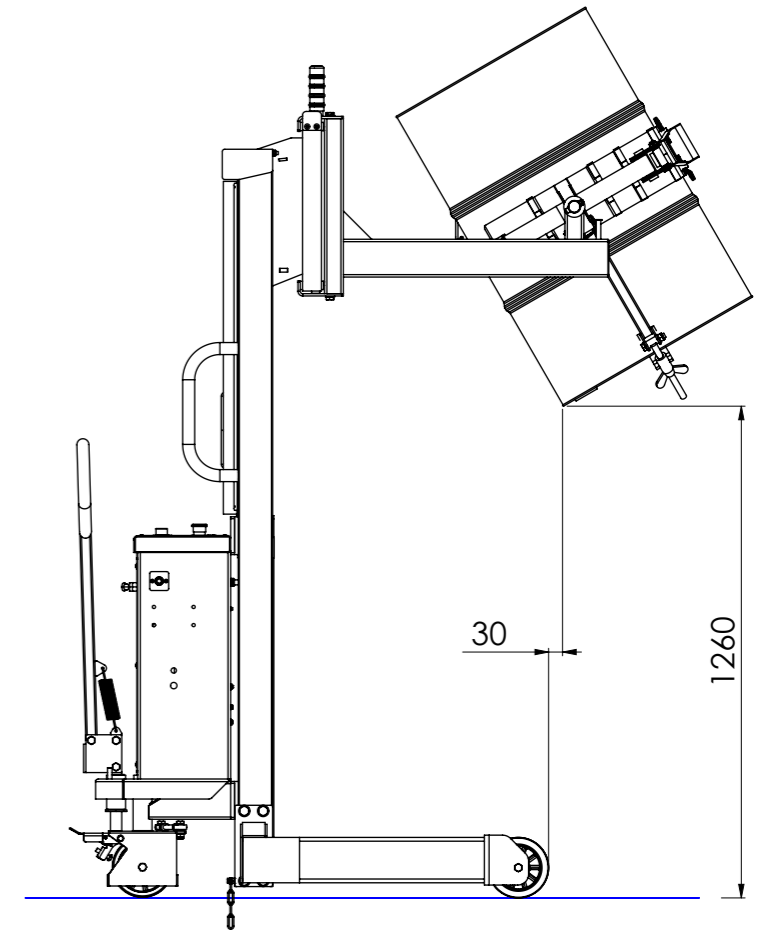

NOTE: STANDARD 205L STEEL DRUM USED FOR TIPPING DIMENSIONS. TIPPING HEIGHT WILL VARY FOR OTHER SIZED DRUMS.



TECRAM
Route d'Yverdon 34 · CH-1373 Chavornay
+41 24 441 42 40 · info@tecram.ch · www.tecram.ch

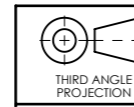

ALL DIMENSIONS
IN mm U.O.S
DO NOT SCALE



BESPOKE HANDLING EQUIPMENT LTD
LEEDSTOWN, CORNWALL, TR27 6DS
TEL: +44 1736 85 10 50 FAX: +44 1736 85 10 23
E-MAIL: SALES@STS-TROLLEYS.CO.UK
WWW: HTTPS://WWW.STS-TROLLEYS.CO.UK

CUSTOMER APPROVAL:
NAME:
SIGNATURE:
DATE:

THIS DOCUMENT AND ALL THE INFORMATION CONTAINED HEREIN ARE CONFIDENTIAL AND EXCLUSIVE PROPERTY OF STS BESPOKE HANDLING EQUIPMENT AND MAY NOT BE REPRODUCED, USED, DISCLOSED OR MADE PUBLIC IN ANY MANNER PRIOR TO EXPRESS WRITTEN AUTHORIZATION BY STS BESPOKE HANDLING EQUIPMENT.
THIS DOCUMENT IS ACCEPTED PURSUANT TO AGREEMENT TO THE FOREGOING, AND MUST BE RETURNED OR DESTROYED UPON DEMAND.
MANUFACTURER AGREES THAT ARTICLES MADE IN ACCORDANCE WITH THIS DOCUMENT SHALL BE CONSIDERED STS BESPOKE HANDLING EQUIPMENT'S DESIGN AND THAT IDENTICAL ARTICLES OR PARTS THEREOF SHALL NOT BE MANUFACTURED FOR THE USE OR SALE BY THE MANUFACTURER OR ANY OTHER PERSON OR ENTITY WITHOUT PRIOR EXPRESS WRITTEN AUTHORIZATION BY STS BESPOKE HANDLING EQUIPMENT.

CATEGORY:	ASSEMBLY
MATERIAL SPEC:	
FINISH:	N/A
DESCRIPTION:	STP01-DRU01-SS-EX, ATEX RATED STAINLESS STEEL PNEUMATIC-HYDRAULIC STACKER WITH A MANUALLY ROTATED UNIVERSAL DRUM BAND, 350KG SWL

SHEET NO:	3 OF 5	DRAWN BY:	JS
EST MASS:	639.00kg	CHECKED BY:	
SHEET SIZE:	A3	DATE CHK:	
PART NUMBER:	018318	REVISION:	B

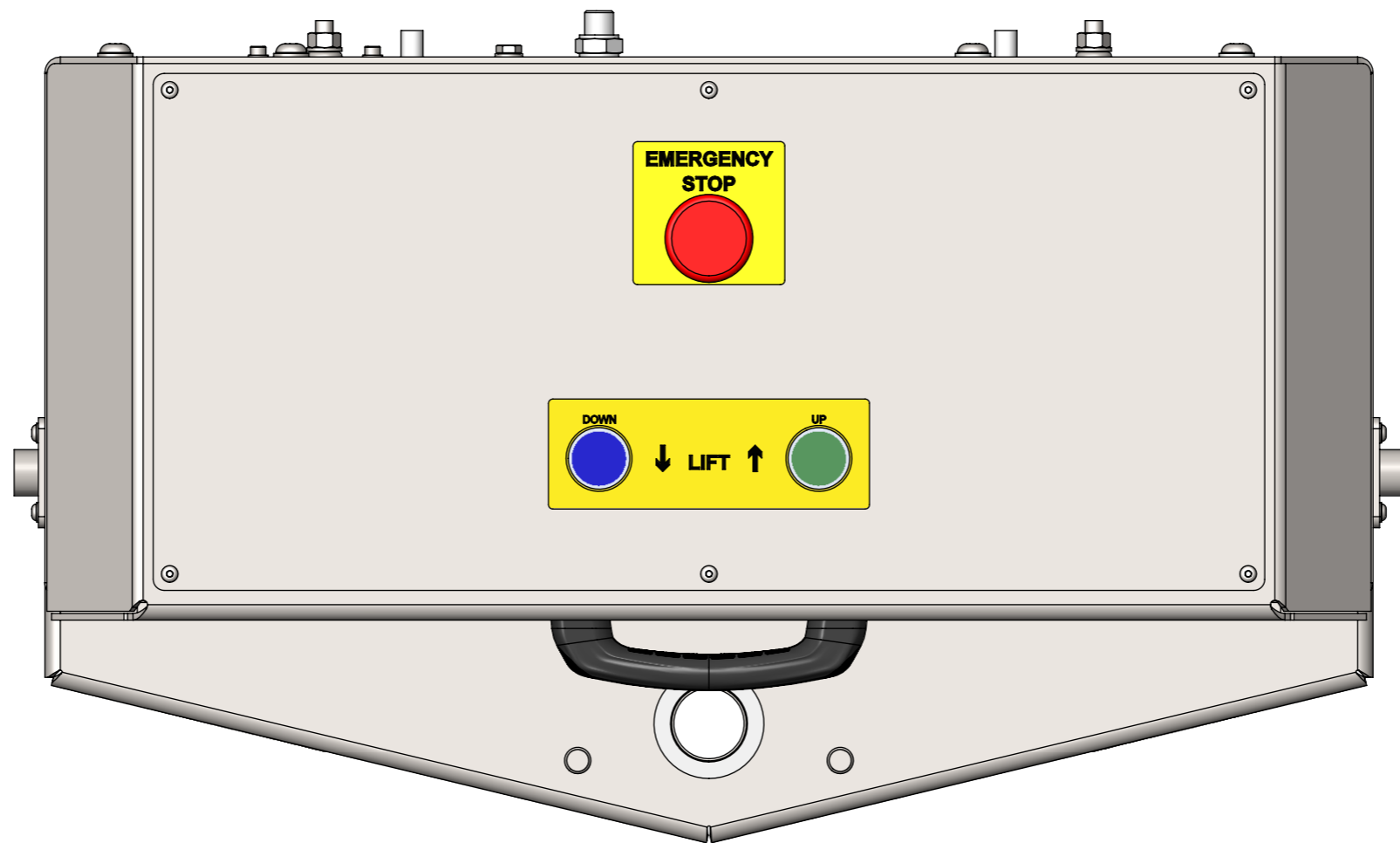

TECRAM
 Route d'Yverdon 34 · CH-1373 Chavornay
 +41 24 441 42 40 · info@tecram.ch · www.tecram.ch



THIRD ANGLE PROJECTION



STN
 BESPOKE HANDLING EQUIPMENT LTD
 LEEDSTOWN, CORNWALL, TR27 6DS
 TEL: +44 1736 85 10 50 FAX: +44 1736 85 10 23
 E-MAIL: SALES@STS-TROLLEYS.CO.UK
 WWW: HTTPS://WWW.STS-TROLLEYS.CO.UK

ALL DIMENSIONS IN mm U.O.S
 DO NOT SCALE

CUSTOMER APPROVAL:
 NAME:
 SIGNATURE:
 DATE:

THIS DOCUMENT AND ALL THE INFORMATION CONTAINED HEREIN ARE CONFIDENTIAL AND EXCLUSIVE PROPERTY OF STS BESPOKE HANDLING EQUIPMENT AND MAY NOT BE REPRODUCED, USED, DISCLOSED OR MADE PUBLIC IN ANY MANNER PRIOR TO EXPRESS WRITTEN AUTHORIZATION BY STS BESPOKE HANDLING EQUIPMENT.
 THIS DOCUMENT IS ACCEPTED PURSUANT TO AGREEMENT TO THE FOREGOING, AND MUST BE RETURNED OR DESTROYED UPON DEMAND.
 MANUFACTURER AGREES THAT ARTICLES MADE IN ACCORDANCE WITH THIS DOCUMENT SHALL BE CONSIDERED STS BESPOKE HANDLING EQUIPMENT'S DESIGN AND THAT IDENTICAL ARTICLES OR PARTS THEREOF SHALL NOT BE MANUFACTURED FOR THE USE OR SALE BY THE MANUFACTURER OR ANY OTHER PERSON OR ENTITY WITHOUT PRIOR EXPRESS WRITTEN AUTHORIZATION BY STS BESPOKE HANDLING EQUIPMENT.

CATEGORY: ASSEMBLY
 MATERIAL SPEC:
 FINISH: N/A
 DESCRIPTION: STP01-DRU01-SS-EX, ATEX RATED STAINLESS STEEL PNEUMATIC-HYDRAULIC STACKER WITH A MANUALLY ROTATED UNIVERSAL DRUM BAND, 350KG SWL

SHEET NO: 4 OF 5
 EST MASS: 639.00kg
 SHEET SIZE: A3
 PART NUMBER: 018318

DRAWN BY: JS
 CHECKED BY:
 DATE CHK:
 REVISION: B