

STE01-DRU01-SS

SWL : 350KG

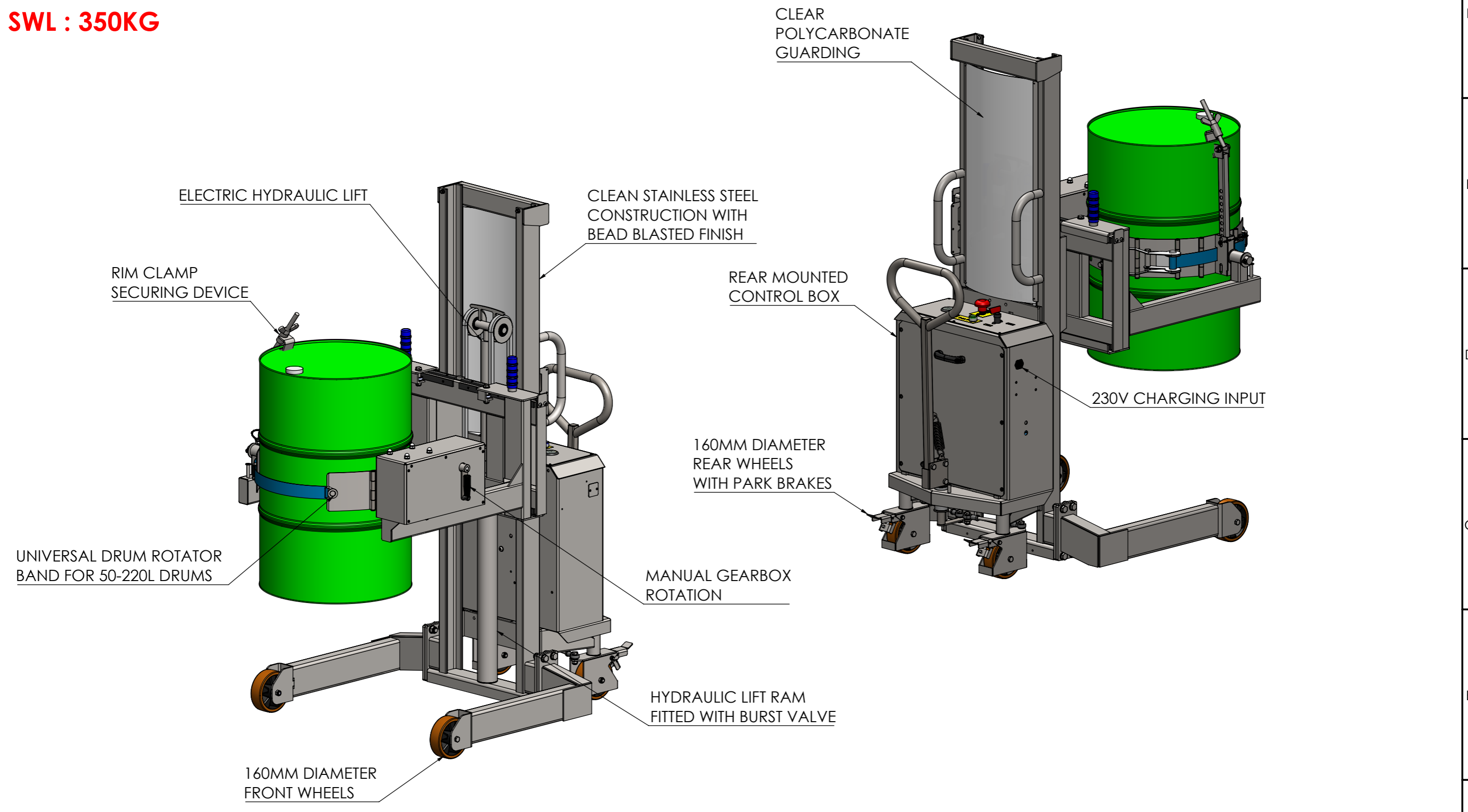

ELECTRIC HYDRAULIC LIFT

RIM CLAMP SECURING DEVICE

CLEAN STAINLESS STEEL CONSTRUCTION WITH BEAD BLASTED FINISH

CLEAR POLYCARBONATE GUARDING

REAR MOUNTED CONTROL BOX

230V CHARGING INPUT

160MM DIAMETER REAR WHEELS WITH PARK BRAKES

MANUAL GEARBOX ROTATION

HYDRAULIC LIFT RAM FITTED WITH BURST VALVE

UNIVERSAL DRUM ROTATOR BAND FOR 50-220L DRUMS

160MM DIAMETER FRONT WHEELS



TECRAM
 Route d'Yverdon 34 · CH-1373 Chavornay
 +41 24 441 42 40 · info@tecram.ch · www.tecram.ch

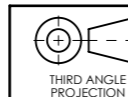

ALL DIMENSIONS IN mm U.O.S
DO NOT SCALE



BESPOKE HANDLING EQUIPMENT LTD
 LEEDSTOWN, CORNWALL, TR27 6DS
 TEL: +44 1736 85 10 50 FAX: +44 1736 85 10 23
 E-MAIL: SALES@STS-TROLLEYS.CO.UK
 WWW: HTTPS://WWW.STS-TROLLEYS.CO.UK

CUSTOMER APPROVAL:
 NAME:
 SIGNATURE:
 DATE:

THIS DOCUMENT AND ALL THE INFORMATION CONTAINED HEREIN ARE CONFIDENTIAL AND EXCLUSIVE PROPERTY OF STS BESPOKE HANDLING EQUIPMENT AND MAY NOT BE REPRODUCED, USED, DISCLOSED OR MADE PUBLIC IN ANY MANNER PRIOR TO EXPRESS WRITTEN AUTHORIZATION BY STS BESPOKE HANDLING EQUIPMENT.
 THIS DOCUMENT IS ACCEPTED PURSUANT TO AGREEMENT TO THE FOREGOING, AND MUST BE RETURNED OR DESTROYED UPON DEMAND.
 MANUFACTURER AGREES THAT ARTICLES MADE IN ACCORDANCE WITH THIS DOCUMENT SHALL BE CONSIDERED STS BESPOKE HANDLING EQUIPMENT'S DESIGN AND THAT IDENTICAL ARTICLES OR PARTS THEREOF SHALL NOT BE MANUFACTURED FOR THE USE OR SALE BY THE MANUFACTURER OR ANY OTHER PERSON OR ENTITY WITHOUT PRIOR EXPRESS WRITTEN AUTHORIZATION BY STS BESPOKE HANDLING EQUIPMENT.

CATEGORY:	ASSEMBLY
MATERIAL SPEC:	
FINISH:	
DESCRIPTION:	STE01-DRU01-SS, STAINLESS STEEL PEDESTRIAN PROPELLED ELECTRIC-HYDRAULIC STACKER WITH A MANUALLY ROTATED UNIVERSAL DRUM BAND

SHEET NO:	1 OF 5	DRAWN BY:	-
EST MASS:	648.10kg	CHECKED BY:	
SHEET SIZE:	A3	DATE CHK:	
PART NUMBER:	016302	REVISION:	B

R1450
TURNING RADIUS

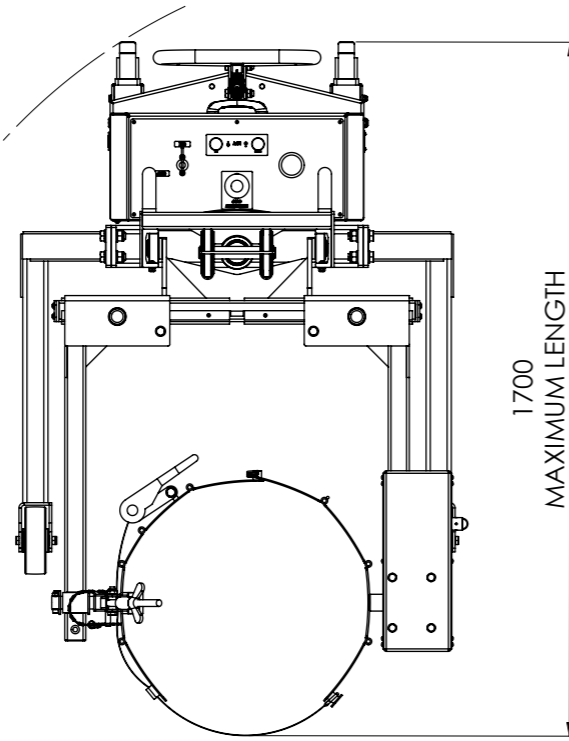

1700
MAXIMUM LENGTH

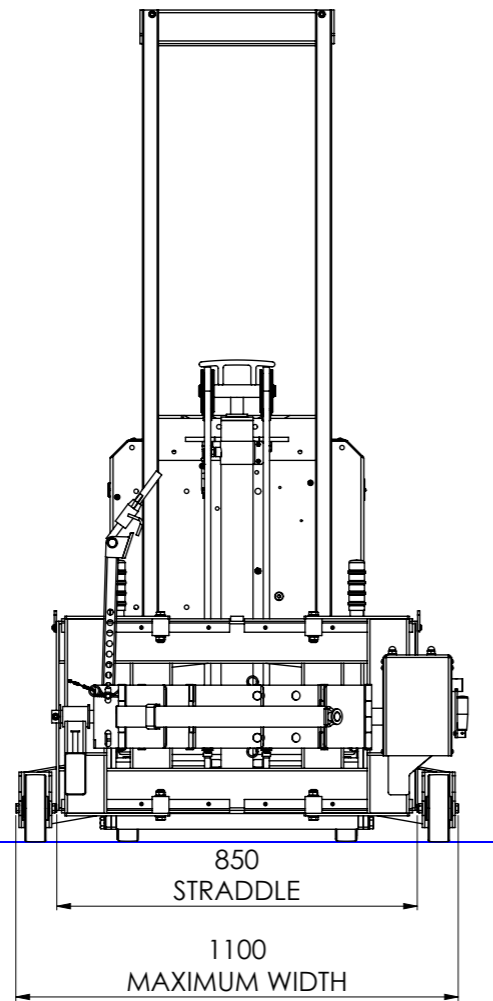

850
STRADDLE
1100
MAXIMUM WIDTH

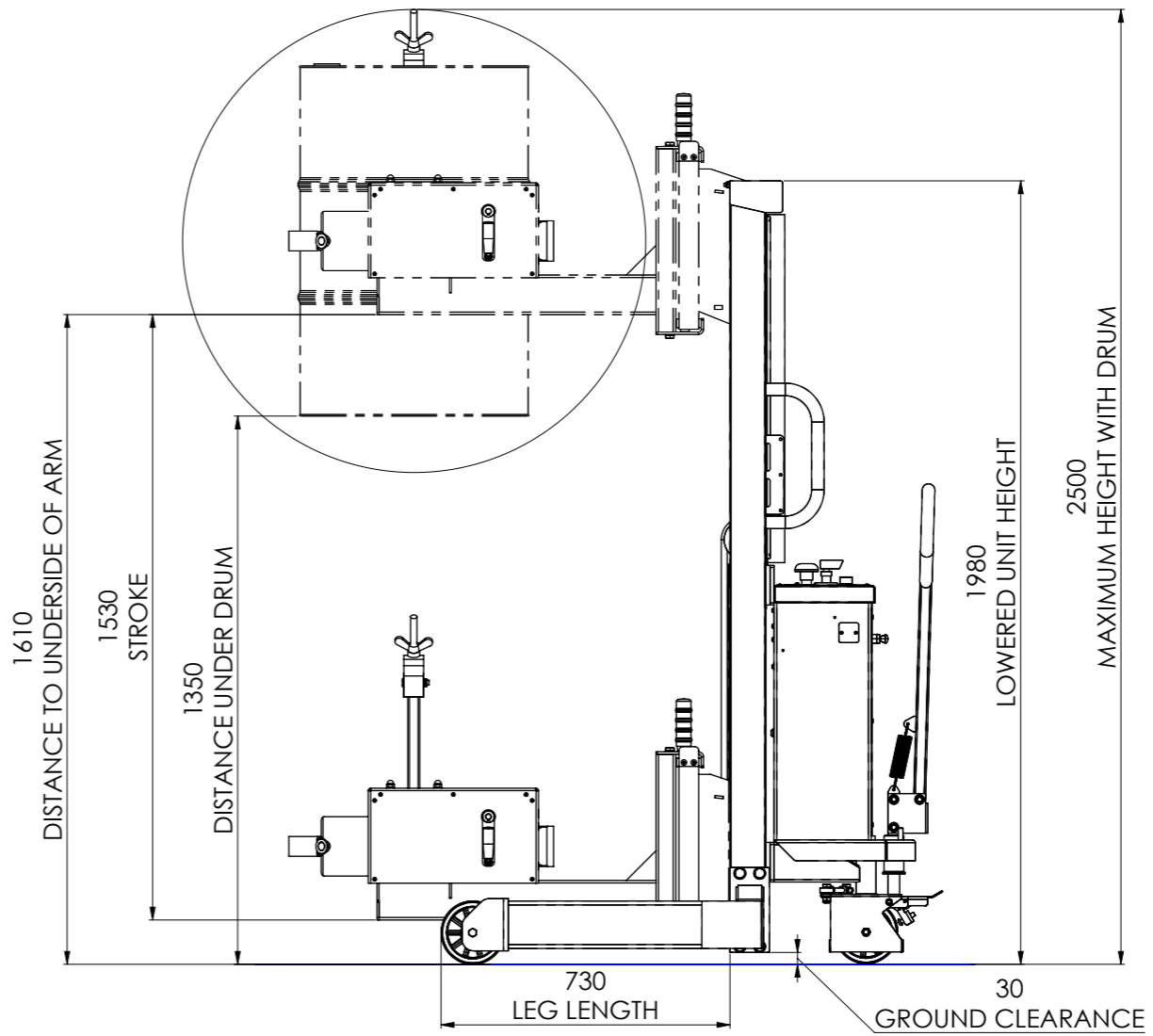

1610
DISTANCE TO UNDERSIDE OF ARM

1530
STROKE

1350
DISTANCE UNDER DRUM

730
LEG LENGTH

1980
LOWERED UNIT HEIGHT

2500
MAXIMUM HEIGHT WITH DRUM

30
GROUND CLEARANCE



Route d'Yverdon 34 · CH-1373 Chavornay
+41 24 441 42 40 · info@tecram.ch · www.tecram.ch

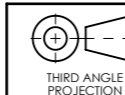

ALL DIMENSIONS
IN mm U.O.S
DO NOT SCALE



BESPOKE HANDLING EQUIPMENT LTD
LEEDSTOWN, CORNWALL, TR27 6DS
TEL: +44 1736 85 10 50 FAX: +44 1736 85 10 23
E-MAIL: SALES@STS-TROLLEYS.CO.UK
WWW: HTTPS://WWW.STS-TROLLEYS.CO.UK

CUSTOMER APPROVAL:

NAME:
SIGNATURE:
DATE:

THIS DOCUMENT AND ALL THE INFORMATION CONTAINED HEREIN ARE CONFIDENTIAL AND EXCLUSIVE PROPERTY OF STS BESPOKE HANDLING EQUIPMENT AND MAY NOT BE REPRODUCED, USED, DISCLOSED OR MADE PUBLIC IN ANY MANNER PRIOR TO EXPRESS WRITTEN AUTHORIZATION BY STS BESPOKE HANDLING EQUIPMENT.
THIS DOCUMENT IS ACCEPTED PURSUANT TO AGREEMENT TO THE FOREGOING, AND MUST BE RETURNED OR DESTROYED UPON DEMAND.
MANUFACTURER AGREES THAT ARTICLES MADE IN ACCORDANCE WITH THIS DOCUMENT SHALL BE CONSIDERED STS BESPOKE HANDLING EQUIPMENT'S DESIGN AND THAT IDENTICAL ARTICLES OR PARTS THEREOF SHALL NOT BE MANUFACTURED FOR THE USE OR SALE BY THE MANUFACTURER OR ANY OTHER PERSON OR ENTITY WITHOUT PRIOR EXPRESS WRITTEN AUTHORIZATION BY STS BESPOKE HANDLING EQUIPMENT.

CATEGORY: ASSEMBLY

MATERIAL SPEC:

FINISH:

DESCRIPTION: STE01-DRU01-SS, STAINLESS STEEL PEDESTRIAN PROPELLED ELECTRIC-HYDRAULIC STACKER WITH A MANUALLY ROTATED UNIVERSAL DRUM BAND

SHEET NO: 2 OF 5

EST MASS: 648.10kg

SHEET SIZE: A3

PART NUMBER:
016302

DRAWN BY: -

CHECKED BY:

DATE
CHK:

REVISION:
B

TIPPING HEIGHTS

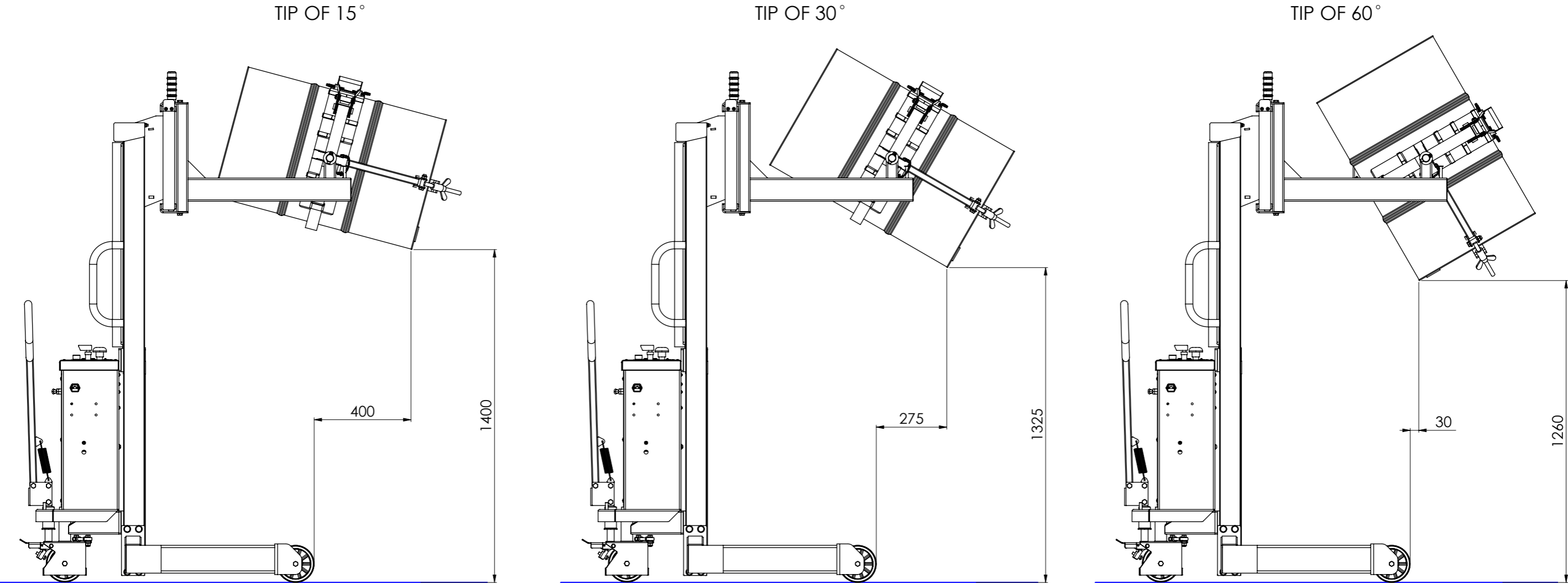

NOTE: STANDARD 205L STEEL DRUM USED FOR TIPPING DIMENSIONS. TIPPING HEIGHT WILL VARY FOR OTHER SIZED DRUMS.



TECRAM
 Route d'Yverdon 34 · CH-1373 Chavornay
 +41 24 441 42 40 · info@tecram.ch · www.tecram.ch

THIRD ANGLE PROJECTION

ALL DIMENSIONS IN mm U.O.S
 DO NOT SCALE



BESPOKE HANDLING EQUIPMENT LTD
 LEEDSTOWN, CORNWALL, TR27 6DS
 TEL: +44 1736 85 10 50 FAX: +44 1736 85 10 23
 E-MAIL: SALES@STS-TROLLEYS.CO.UK
 WWW: HTTPS://WWW.STS-TROLLEYS.CO.UK

CUSTOMER APPROVAL:

NAME:

SIGNATURE:

DATE:

THIS DOCUMENT AND ALL THE INFORMATION CONTAINED HEREIN ARE CONFIDENTIAL AND EXCLUSIVE PROPERTY OF STS BESPOKE HANDLING EQUIPMENT AND MAY NOT BE REPRODUCED, USED, DISCLOSED OR MADE PUBLIC IN ANY MANNER PRIOR TO EXPRESS WRITTEN AUTHORIZATION BY STS BESPOKE HANDLING EQUIPMENT.
 THIS DOCUMENT IS ACCEPTED PURSUANT TO AGREEMENT TO THE FOREGOING, AND MUST BE RETURNED OR DESTROYED UPON DEMAND.
 MANUFACTURER AGREES THAT ARTICLES MADE IN ACCORDANCE WITH THIS DOCUMENT SHALL BE CONSIDERED STS BESPOKE HANDLING EQUIPMENT'S DESIGN AND THAT IDENTICAL ARTICLES OR PARTS THEREOF SHALL NOT BE MANUFACTURED FOR THE USE OR SALE BY THE MANUFACTURER OR ANY OTHER PERSON OR ENTITY WITHOUT PRIOR EXPRESS WRITTEN AUTHORIZATION BY STS BESPOKE HANDLING EQUIPMENT.

CATEGORY:	ASSEMBLY
MATERIAL SPEC:	
FINISH:	
DESCRIPTION:	STE01-DRU01-SS, STAINLESS STEEL PEDESTRIAN PROPELLED ELECTRIC-HYDRAULIC STACKER WITH A MANUALLY ROTATED UNIVERSAL DRUM BAND

SHEET NO:	3 OF 5	DRAWN BY:	-
EST MASS:	648.10kg	CHECKED BY:	
SHEET SIZE:	A3	DATE CHK:	
PART NUMBER:	016302	REVISION:	B

CONTROL BOX

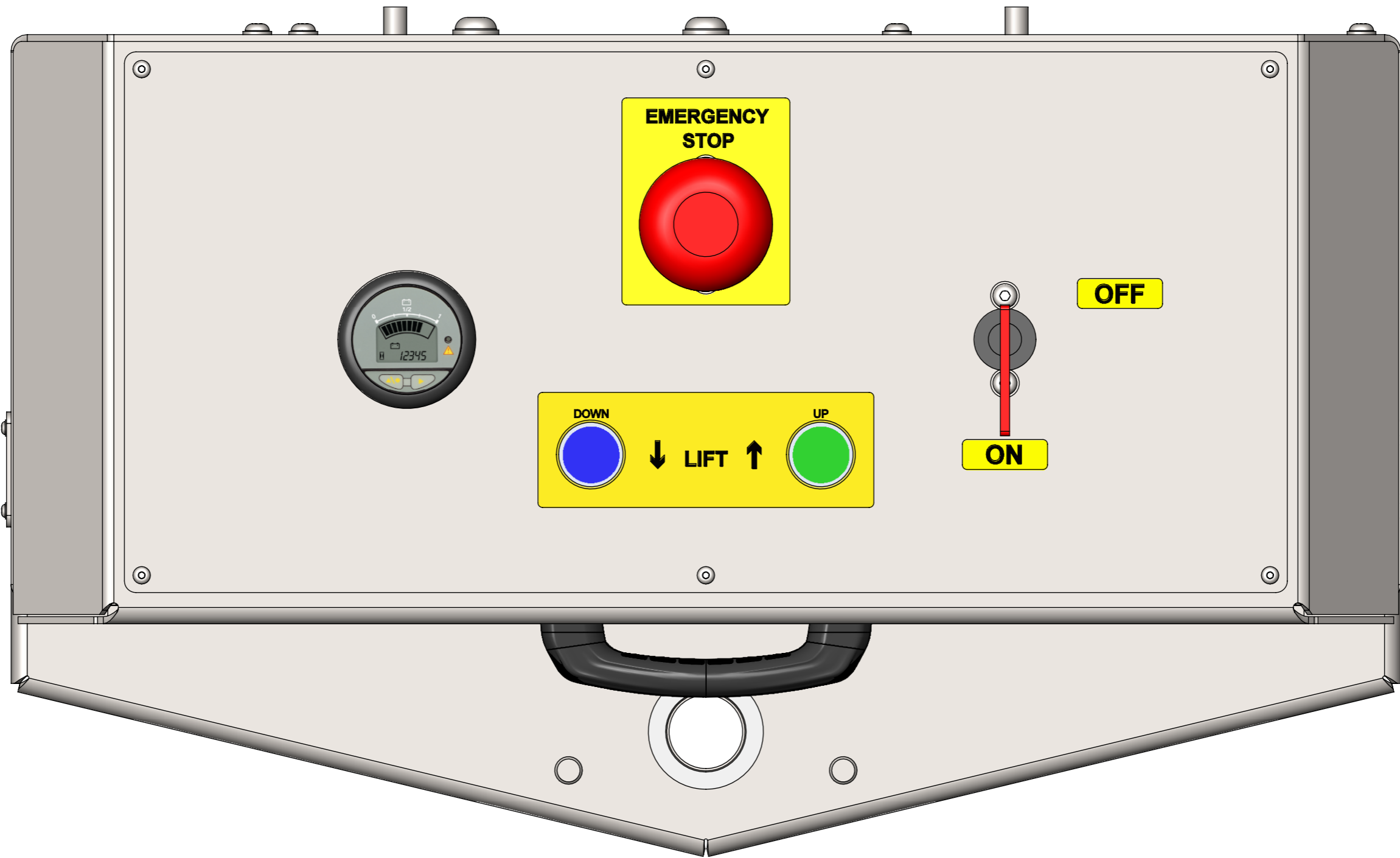

TECRAM
 Route d'Yverdon 34 · CH-1373 Chavornay
 +41 24 441 42 40 · info@tecram.ch · www.tecram.ch

THIRD ANGLE PROJECTION

ALL DIMENSIONS IN mm U.O.S
 DO NOT SCALE



STN
 BESPOKE HANDLING EQUIPMENT LTD
 LEEDSTOWN, CORNWALL, TR27 6DS
 TEL: +44 1736 85 10 50 FAX: +44 1736 85 10 23
 E-MAIL: SALES@STS-TROLLEYS.CO.UK
 WWW: HTTPS://WWW.STS-TROLLEYS.CO.UK

CUSTOMER APPROVAL:

NAME:

SIGNATURE:

DATE:

THIS DOCUMENT AND ALL THE INFORMATION CONTAINED HEREIN ARE CONFIDENTIAL AND EXCLUSIVE PROPERTY OF STS BESPOKE HANDLING EQUIPMENT AND MAY NOT BE REPRODUCED, USED, DISCLOSED OR MADE PUBLIC IN ANY MANNER PRIOR TO EXPRESS WRITTEN AUTHORIZATION BY STS BESPOKE HANDLING EQUIPMENT. THIS DOCUMENT IS ACCEPTED PURSUANT TO AGREEMENT TO THE FOREGOING, AND MUST BE RETURNED OR DESTROYED UPON DEMAND. MANUFACTURER AGREES THAT ARTICLES MADE IN ACCORDANCE WITH THIS DOCUMENT SHALL BE CONSIDERED STS BESPOKE HANDLING EQUIPMENT'S DESIGN AND THAT IDENTICAL ARTICLES OR PARTS THEREOF SHALL NOT BE MANUFACTURED FOR THE USE OR SALE BY THE MANUFACTURER OR ANY OTHER PERSON OR ENTITY WITHOUT PRIOR EXPRESS WRITTEN AUTHORIZATION BY STS BESPOKE HANDLING EQUIPMENT.

CATEGORY: ASSEMBLY

MATERIAL SPEC:

FINISH:

DESCRIPTION: STE01-DRU01-SS, STAINLESS STEEL PEDESTRIAN PROPELLED ELECTRIC-HYDRAULIC STACKER WITH A MANUALLY ROTATED UNIVERSAL DRUM BAND

SHEET NO: 4 OF 5	DRAWN BY: -
EST MASS: 648.10kg	CHECKED BY:
SHEET SIZE: A3	DATE CHK:
PART NUMBER: 016302	REVISION: B