

**STE01-DRU01**  
**SWL: 350KG**

ELECTRIC HYDRAULIC LIFT

CLEAN MILD STEEL  
CONSTRUCTION WITH  
POWDER COATED FINISH

RIM CLAMP  
SECURING DEVICE

CLEAR  
POLYCARBONATE  
GUARDING

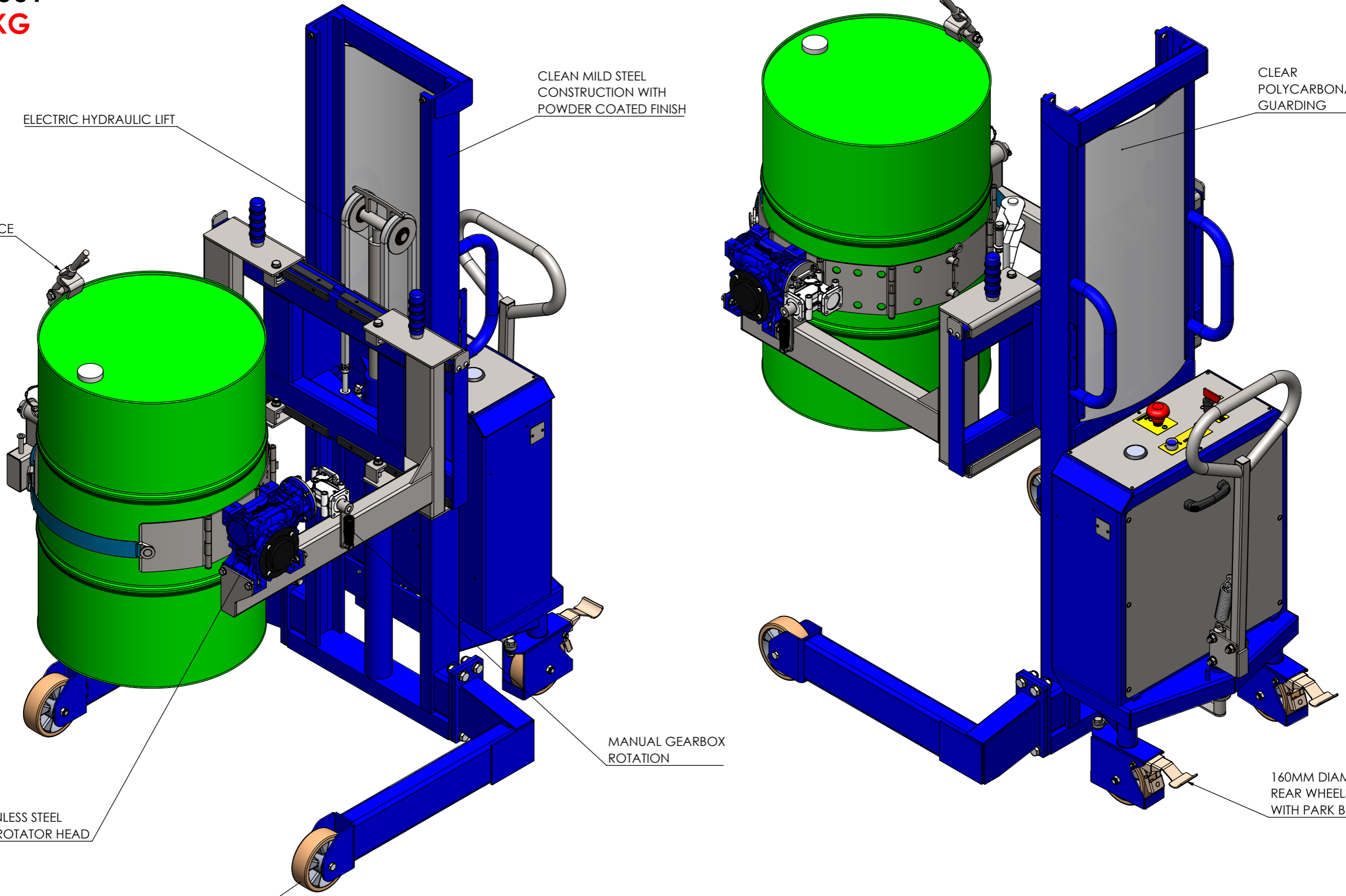

DRU01 STAINLESS STEEL  
UNIVERSAL ROTATOR HEAD

160MM DIAMETER  
FRONT WHEELS

MANUAL GEARBOX  
ROTATION

160MM DIAMETER  
REAR WHEELS  
WITH PARK BRAKES



**TECRAM**  
Route d'Yverdon 34 · CH-1373 Chavornay  
+41 24 441 42 40 · info@tecram.ch · www.tecram.ch

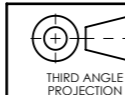

ALL DIMENSIONS  
IN mm U.O.S  
DO NOT SCALE



BESPOKE HANDLING EQUIPMENT LTD  
LEEDSTOWN, CORNWALL, TR27 6DS  
TEL: +44 1736 85 10 50 FAX: +44 1736 85 10 23  
E-MAIL: SALES@STS-TROLLEYS.CO.UK  
WWW: HTTPS://WWW.STS-TROLLEYS.CO.UK

CUSTOMER APPROVAL:

NAME: .....  
SIGNATURE: .....  
DATE: .....

THIS DOCUMENT AND ALL THE INFORMATION CONTAINED HEREIN ARE CONFIDENTIAL AND EXCLUSIVE PROPERTY OF STS BESPOKE HANDLING EQUIPMENT AND MAY NOT BE REPRODUCED, USED, DISCLOSED OR MADE PUBLIC IN ANY MANNER PRIOR TO EXPRESS WRITTEN AUTHORIZATION BY STS BESPOKE HANDLING EQUIPMENT. THIS DOCUMENT IS ACCEPTED PURSUANT TO AGREEMENT TO THE FOREGOING, AND MUST BE RETURNED OR DESTROYED UPON DEMAND. MANUFACTURER AGREES THAT ARTICLES MADE IN ACCORDANCE WITH THIS DOCUMENT SHALL BE CONSIDERED STS BESPOKE HANDLING EQUIPMENT'S DESIGN AND THAT IDENTICAL ARTICLES OR PARTS THEREOF SHALL NOT BE MANUFACTURED FOR THE USE OR SALE BY THE MANUFACTURER OR ANY OTHER PERSON OR ENTITY WITHOUT PRIOR EXPRESS WRITTEN AUTHORIZATION BY STS BESPOKE HANDLING EQUIPMENT.

CATEGORY: ASSEMBLY

MATERIAL SPEC:

FINISH: N/A

DESCRIPTION: STE01-DRU01, PEDESTRIAN PROPELLED ELECTRIC HYDRAULIC STACKER WITH MANUAL DRUM ROTATION, 350KG SWL

SHEET NO: 1 OF 5

EST MASS: 652.53kg

SHEET SIZE: A3

PART NUMBER:  
001402

DRAWN BY: JS

CHECKED BY: JC

DATE CHK: 17/02/2021

REVISION:  
B

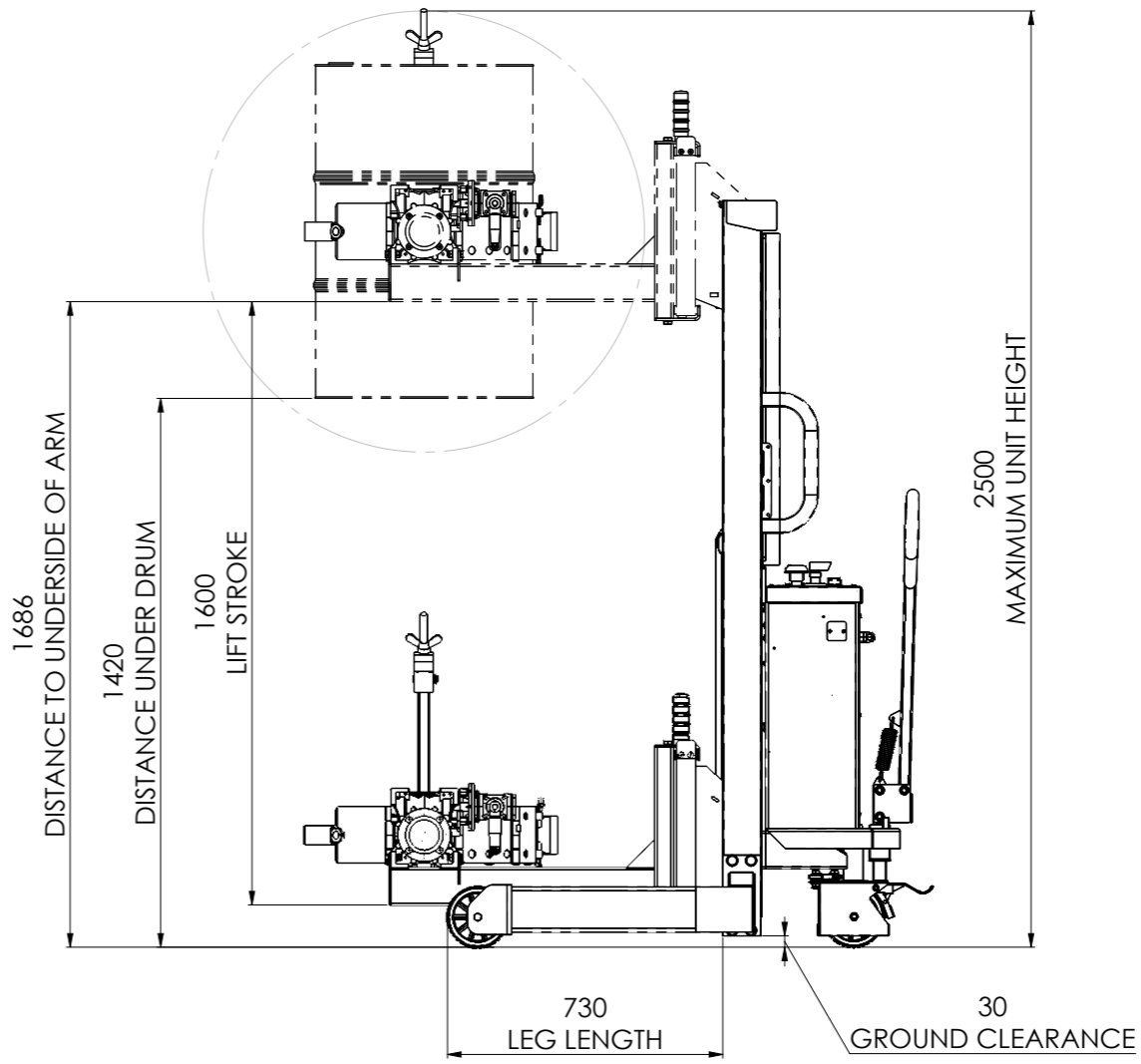
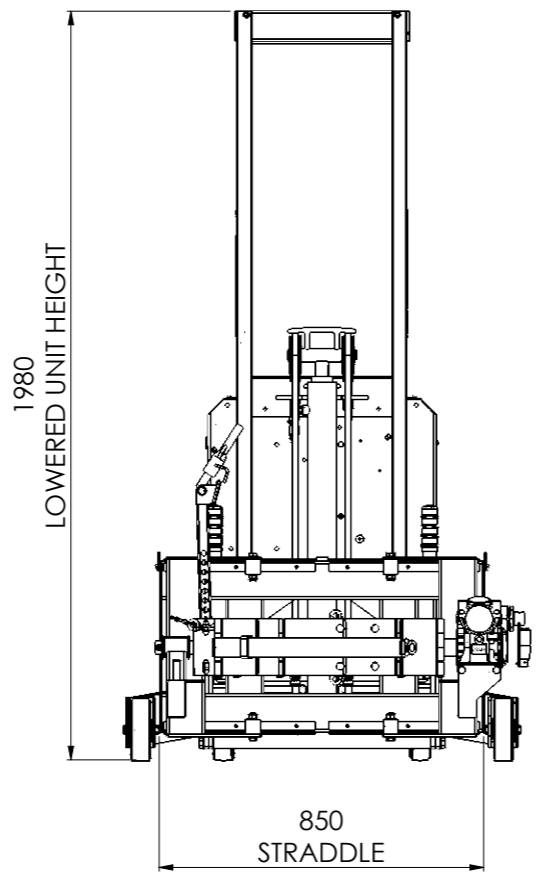
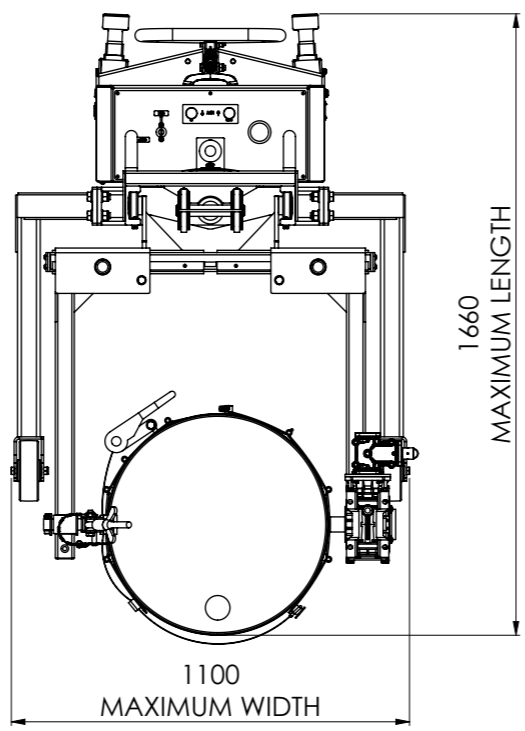

Route d'Yverdon 34 · CH-1373 Chavornay  
+41 24 441 42 40 · info@tecram.ch · www.tecram.ch

THIRD ANGLE PROJECTION

ALL DIMENSIONS IN mm U.O.S  
DO NOT SCALE

**STS**  
BESPOKE HANDLING EQUIPMENT LTD  
LEEDSTOWN, CORNWALL, TR27 6DS  
TEL: +44 1736 85 10 50 FAX: +44 1736 85 10 23  
E-MAIL: SALES@STS-TROLLEYS.CO.UK  
WWW: HTTPS://WWW.STS-TROLLEYS.CO.UK

CUSTOMER APPROVAL:

NAME: .....

SIGNATURE: .....

DATE: .....

THIS DOCUMENT AND ALL THE INFORMATION CONTAINED HEREIN ARE CONFIDENTIAL AND EXCLUSIVE PROPERTY OF STS BESPOKE HANDLING EQUIPMENT AND MAY NOT BE REPRODUCED, USED, DISCLOSED OR MADE PUBLIC IN ANY MANNER PRIOR TO EXPRESS WRITTEN AUTHORIZATION BY STS BESPOKE HANDLING EQUIPMENT.  
THIS DOCUMENT IS ACCEPTED PURSUANT TO AGREEMENT TO THE FOREGOING, AND MUST BE RETURNED OR DESTROYED UPON DEMAND.  
MANUFACTURER AGREES THAT ARTICLES MADE IN ACCORDANCE WITH THIS DOCUMENT SHALL BE CONSIDERED STS BESPOKE HANDLING EQUIPMENT'S DESIGN AND THAT IDENTICAL ARTICLES OR PARTS THEREOF SHALL NOT BE MANUFACTURED FOR THE USE OR SALE BY THE MANUFACTURER OR ANY OTHER PERSON OR ENTITY WITHOUT PRIOR EXPRESS WRITTEN AUTHORIZATION BY STS BESPOKE HANDLING EQUIPMENT.

CATEGORY: ASSEMBLY

MATERIAL SPEC:

FINISH: N/A

DESCRIPTION: STE01-DRU01, PEDESTRIAN PROPELLED ELECTRIC HYDRAULIC STACKER WITH MANUAL DRUM ROTATION, 350KG SWL

|                     |                      |
|---------------------|----------------------|
| SHEET NO: 2 OF 5    | DRAWN BY: JS         |
| EST MASS: 652.53kg  | CHECKED BY: JC       |
| SHEET SIZE: A3      | DATE CHK: 17/02/2021 |
| PART NUMBER: 001402 | REVISION: B          |

# TIPPING HEIGHTS

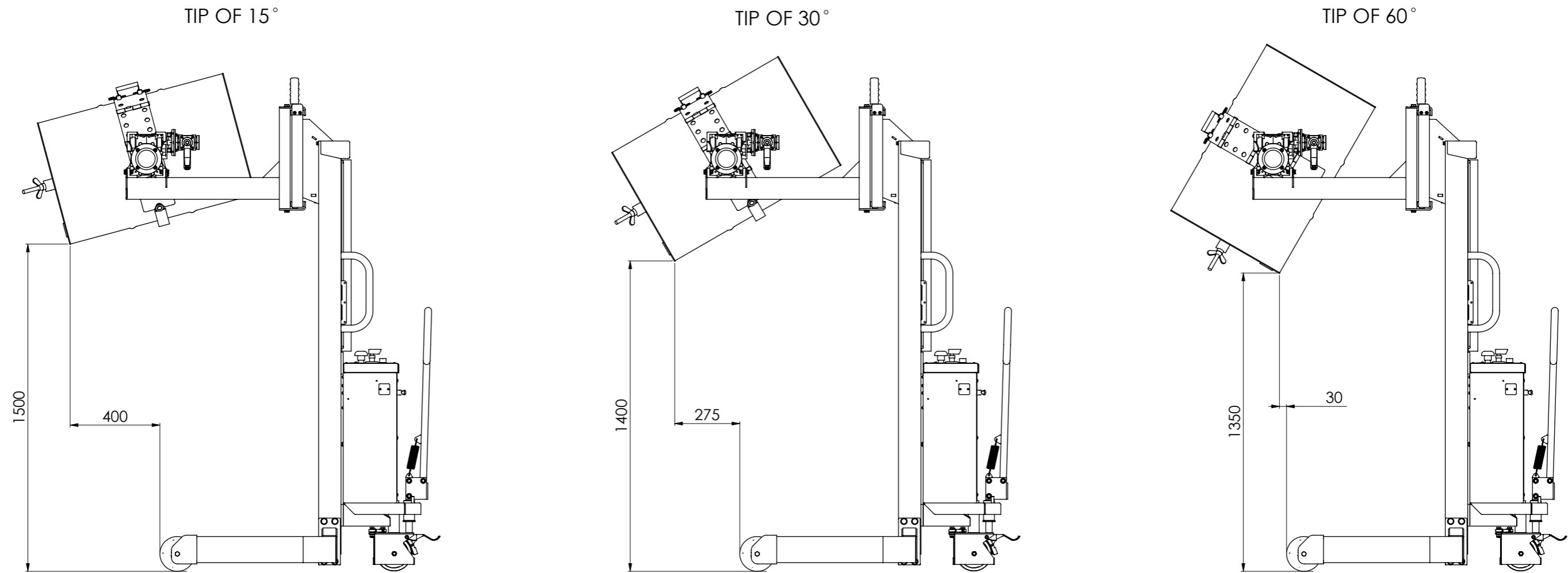

NOTE: STANDARD 205L STEEL DRUM USED FOR TIPPING DIMENSIONS. TIPPING HEIGHT WILL VARY FOR OTHER SIZED DRUMS



**TECRAM**  
Route d'Yverdon 34 · CH-1373 Chavornay  
+41 24 441 42 40 · info@tecram.ch · www.tecram.ch

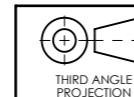

ALL DIMENSIONS  
IN mm U.O.S  
DO NOT SCALE



BESPOKE HANDLING EQUIPMENT LTD  
LEEDSTOWN, CORNWALL, TR27 6DS  
TEL: +44 1736 85 10 50 FAX: +44 1736 85 10 23  
E-MAIL: SALES@STS-TROLLEYS.CO.UK  
WWW: HTTPS://WWW.STS-TROLLEYS.CO.UK

CUSTOMER APPROVAL:  
NAME: .....  
SIGNATURE: .....  
DATE: .....

THIS DOCUMENT AND ALL THE INFORMATION CONTAINED HEREIN ARE CONFIDENTIAL AND EXCLUSIVE PROPERTY OF STS BESPOKE HANDLING EQUIPMENT AND MAY NOT BE REPRODUCED, USED, DISCLOSED OR MADE PUBLIC IN ANY MANNER PRIOR TO EXPRESS WRITTEN AUTHORIZATION BY STS BESPOKE HANDLING EQUIPMENT.  
THIS DOCUMENT IS ACCEPTED PURSUANT TO AGREEMENT TO THE FOREGOING, AND MUST BE RETURNED OR DESTROYED UPON DEMAND.  
MANUFACTURER AGREES THAT ARTICLES MADE IN ACCORDANCE WITH THIS DOCUMENT SHALL BE CONSIDERED STS BESPOKE HANDLING EQUIPMENT'S DESIGN AND THAT IDENTICAL ARTICLES OR PARTS THEREOF SHALL NOT BE MANUFACTURED FOR THE USE OR SALE BY THE MANUFACTURER OR ANY OTHER PERSON OR ENTITY WITHOUT PRIOR EXPRESS WRITTEN AUTHORIZATION BY STS BESPOKE HANDLING EQUIPMENT.

|                |   |              |          |             |            |
|----------------|---|--------------|----------|-------------|------------|
| CATEGORY:      | ASSEMBLY  | SHEET NO:    | 3 OF 5   | DRAWN BY:   | JS         |
| MATERIAL SPEC: |   | EST MASS:    | 652.53kg | CHECKED BY: | JC         |
| FINISH:        | N/A   | SHEET SIZE:  | A3       | DATE CHK:   | 17/02/2021 |
| DESCRIPTION:   | STE01-DRU01, PEDESTRIAN PROPELLED ELECTRIC HYDRAULIC STACKER WITH MANUAL DRUM ROTATION, 350KG SWL | PART NUMBER: | 001402   | REVISION:   | B          |

# CONTROL PANEL LAYOUT

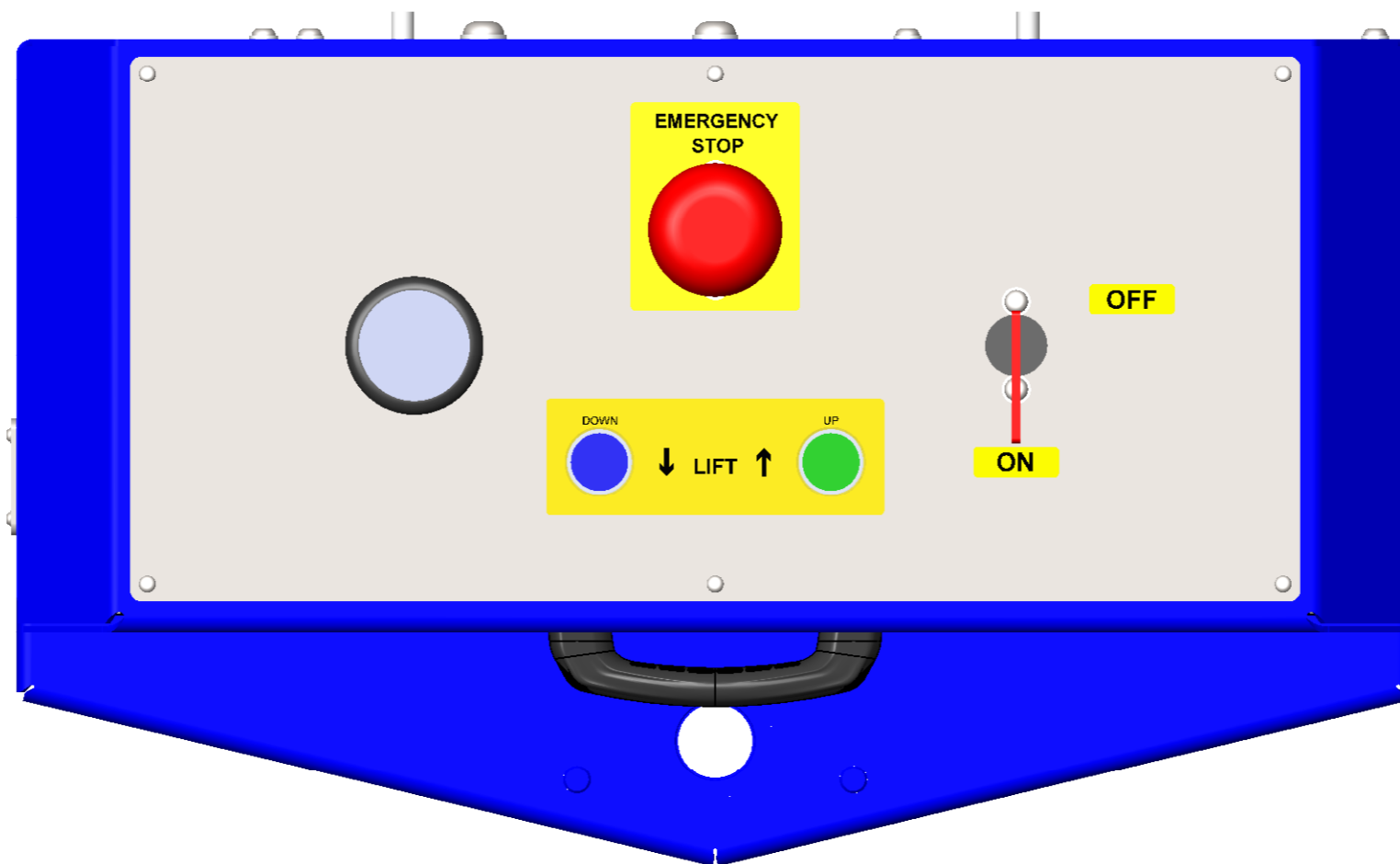

**TECRAM**  
 Route d'Yverdon 34 · CH-1373 Chavornay  
 +41 24 441 42 40 · info@tecram.ch · www.tecram.ch

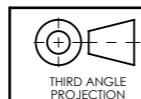

ALL DIMENSIONS  
 IN mm U.O.S  
 DO NOT SCALE



BESPOKE HANDLING EQUIPMENT LTD  
 LEEDSTOWN, CORNWALL, TR27 6DS  
 TEL: +44 1736 85 10 50 FAX: +44 1736 85 10 23  
 E-MAIL: SALES@STS-TROLLEYS.CO.UK  
 WWW: HTTPS://WWW.STS-TROLLEYS.CO.UK

CUSTOMER APPROVAL:  
 NAME: .....  
 SIGNATURE: .....  
 DATE: .....

THIS DOCUMENT AND ALL THE INFORMATION CONTAINED HEREIN ARE CONFIDENTIAL AND EXCLUSIVE PROPERTY OF STS BESPOKE HANDLING EQUIPMENT AND MAY NOT BE REPRODUCED, USED, DISCLOSED OR MADE PUBLIC IN ANY MANNER PRIOR TO EXPRESS WRITTEN AUTHORIZATION BY STS BESPOKE HANDLING EQUIPMENT.  
 THIS DOCUMENT IS ACCEPTED PURSUANT TO AGREEMENT TO THE FOREGOING, AND MUST BE RETURNED OR DESTROYED UPON DEMAND.  
 MANUFACTURER AGREES THAT ARTICLES MADE IN ACCORDANCE WITH THIS DOCUMENT SHALL BE CONSIDERED STS BESPOKE HANDLING EQUIPMENT'S DESIGN AND THAT IDENTICAL ARTICLES OR PARTS THEREOF SHALL NOT BE MANUFACTURED FOR THE USE OR SALE BY THE MANUFACTURER OR ANY OTHER PERSON OR ENTITY WITHOUT PRIOR EXPRESS WRITTEN AUTHORIZATION BY STS BESPOKE HANDLING EQUIPMENT.

CATEGORY: ASSEMBLY  
 MATERIAL SPEC:  
 FINISH: N/A  
 DESCRIPTION: STE01-DRU01, PEDESTRIAN PROPELLED ELECTRIC HYDRAULIC STACKER WITH MANUAL DRUM ROTATION, 350KG SWL

|                     |                      |
|---------------------|----------------------|
| SHEET NO: 4 OF 5    | DRAWN BY: JS         |
| EST MASS: 652.53kg  | CHECKED BY: JC       |
| SHEET SIZE: A3      | DATE CHK: 17/02/2021 |
| PART NUMBER: 001402 | REVISION: B          |